

FIXER

FLAT ROOFING



FLEXI-GRP

Flexible GRP for Multi Surface Application

**15 YEAR
GUARANTEE***

**20 YEAR
GUARANTEE***

**25 YEAR
GUARANTEE***

PRODUCT SELECTOR & QUICK INSTALLATION GUIDE



FLAT ROOFING

THE FLEXIBLE PERFORMANCE GRP ROOFING SYSTEM OF CHOICE

FIX-R have been at the forefront for many years supplying the roofing market with quality flat roofing systems and this is no exception with the introduction of **FIX-R FLEXI GRP**, developed alongside trusted installers and manufactured to the highest standards using only virgin materials in its production.

Contents

- FLEXI-GRP Overview
- FLEXI-GRP Product Range
- GRP Application tools & accessories
- GRP Roofing Trims
- Preparation
- OSB3 Installation Guide
- Surface Preparation-Overlay
- GRP Trims Installation Guide
- Catalyst Addition Chart
- Product Application & Consumption Guides
- Frequently Asked Questions

Why FIX-R FLEXI-GRP

FIX-R FLEXI-GRP is the new innovation in the flat roofing market, making the process of refurbishment or new roofs a simple, effective and long lasting one. FLEXI-GRP takes traditional GRP to the next stage of evolution for roofing, giving a seamless and flexible finish that won't crack or peel and can be used on new or old surfaces.

You can purchase FIX-R products with the confidence that we will be here to support you now and in the future, as we:

- Support customers with technical advice.
- Work with trade associations, training and testing organisations.
- Have an in-depth understanding of market and legislative compliance.

Simple and fast installation with the FIX-R FLEXI-GRP system and accessories from the FIX-R GRP range

WHAT MAKES FIX-R FLEXI-GRP THE RIGHT CHOICE FOR YOU:

- 15-year (300g CSM), 20-year (450g CSM) or 25-year (600g CSM) Material Guarantee when installed correctly, please contact us for further details of the guarantee conditions.
- Single high-performance flexible resin used both as base and topcoat wet-on-wet application
- Can be applied to multiple surfaces for existing and new surfaces such as mineral felt, single ply, GRP, concrete, OSB3, asphalt
- Quick application and cure times
- Cold applied, no hot works or open flame risks
- Class beating Fire rating
Tested as a Flat Roofing System applied to OSB3 and has achieved both:
BS 476-part 3 test:- EXT.F.AA;
EN 1187 test 4 - BROOF(t4)
- Superior 'wet-out' of resin with fiberglass reinforcement (CSM).

Whether it's a small or large flat roof, a refurbishment or a new build, our FLEXI-GRP system is the perfect choice for you.

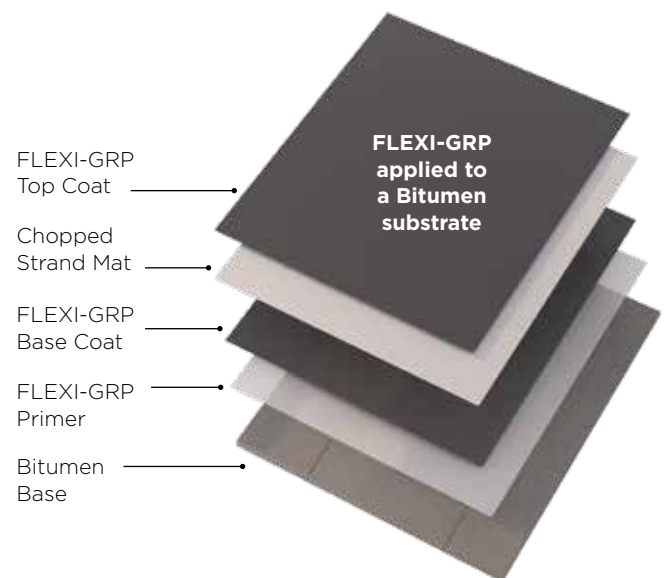
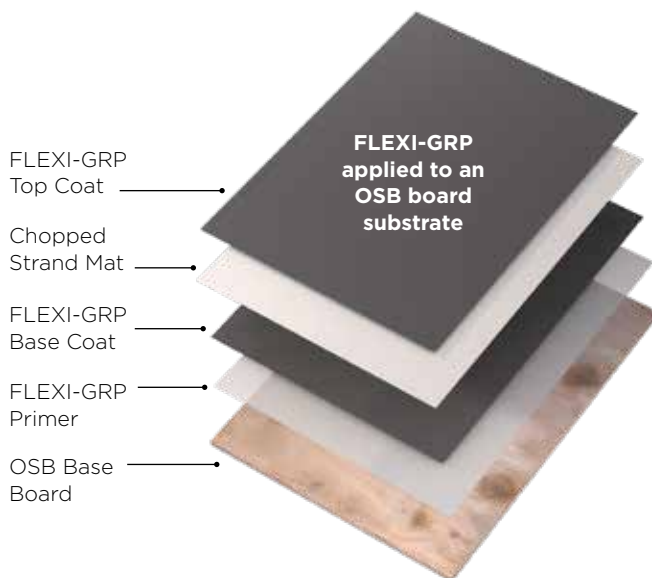

**15 YEAR
GUARANTEE***

**20 YEAR
GUARANTEE***

**25 YEAR
GUARANTEE***

*Please refer to
Materials Usage
Guides on pages
25, 26 & 27

GRP PRODUCT RANGE



FLEXI-GRP

Developed to achieve a consistent curing speed when used with FIX-R GRP Catalyst.

Features:

- Available in 18kg tins 1.25kg/m² coverage approx with 300g csm.
- Designed to be used with FIX-R GRP Catalyst and FIX-R GRP Chopped Strand Matting.



FLEXI-GRP PRIMER

For use when overlaying existing roofing substrates or on new surfaces must be used with FIX-R Catalyst.

Features:

- Available in 5kg tins 250g/m² coverage approx.
- Pigmented white to give clear visibility of application.



FIX-R Standard/Winter Catalyst

FIX-R GRP Catalyst is used to start the reactive curing process for FLEXI-GRP and FLEXI-GRP Primer.



FIX-R GRP Iron Silicate

Iron Silicate enables our GRP systems to be used for walkways and balconies creating an anti slip surface.

Features:

- Available in 5kg, 10kg buckets and 25kg bags.



FIX-R GRP Woven Glass Tape

Woven tape is used to bandage the joints in square edged OSB3, join roof edge trims & corners together and cover/fill small gaps, producing a clean and neat finish. Simply cut the required length and wet out with resin onto the surface.

Features:

- Available in 50m rolls in 50mm, 75mm & 100mm widths.



FIX-R GRP Chopped Strand Matting

A randomly chopped strand matting used in the layering and continuous lamination of FIX-R GRP installations.

Features:

- Consistent quality, thickness and rigidity.
- Rapid wet out and air release.
- Excellent formability for small radius moulds.
- Good mechanical properties.



FIX ALL High Tack Trim Adhesive/Sealer

A high quality, single component joint sealant with high adhesive strength. In addition this product is both weatherproof and waterproof, which makes it ideal for FIX-R GRP System.

For use with FIX-R GRP Trims prior to mechanically fixing.



FIX-R GRP Acetone

Used to clean uncured resin and topcoat from brushes, rollers and other equipment. Please note this material is highly flammable. Available in 1, 5 or 25 litre packs.

GRP TOOLS & ACCESSORIES



Catalyst Dispensers 15ml & 80ml

Catalyst Measuring Cup 500ml

2.5, 5 & 10L Buckets



Paddle Rollers (Available in 70 x 21mm, 140 x 21mm, 180 x 21mm, 180 x 40mm, 225 x 40mm)



Fin Rollers (Available in 35 x 12mm, 70 x 12mm)



Large Bubble Buster Roller
(Available in 140 x 21mm, 225 x 21mm)



Resin Application Rollers (Available in 3", 6", 7" & 9")

Roller Frame Only (Available in 3", 6", 7" & 9")



Resin Roller Refills (Available in 3", 6", 7" & 9")

Push Fit Roller Frame (Available in 6", 7" & 10")



Topcoat Roller Refill (velour) (Available in 5", 6", 7" & 10")

Telescopic Pole 80cm - 140cm with Taper & Screw Cone

Wooden handled brushes (Available in 2", 3" & 4")

Plastic handled brushes (Available in 2", 3" & 4")



Disposable Powdered Gloves Large box of 100.

Roofing and tool kits available, please ask for details

GRP ROOFING TRIMS

Our GRP Roofing Trims are manufactured in the UK using quality resin and glass fibre. All trims are finished in a light grey colour and cut to a 2.5m length, designed for ease of handling and to reduce waste on installations with the exception of both the “F” range and corner trims. The trims have a high adhesion matt finish to the outer face for the GRP laminate and topcoat.

- Standard 2.5m length.
- Consistent weight and thickness.
- Easy jointing - simple overlap by 50mm.

See Installation Guide for full fitting instructions.



FIX-R GRP B240/B260 Trims

Raised edge trims are used to channel rainwater away from the edges to the guttering. Fascia should be pre-fitted with batten to ensure the trim is supported.

- B240 (100 x 105mm)
- B260 (130 x 125mm)



FIX-R GRP A170/A200/A250 Drip Trims

These trims are fitted to lowest edge of the roof of roof where water flows into the gutter allowing for drainage.

- A170 (75 x 84mm)
- A200 (95 x 90mm)
- A200A (90 x 90mm) - same A200, but with drip return
- A250 (95 x 140mm)

FIX-R GRP C1/C2/C3/C4 Corner Trims

Corner trims are used to neatly join and finish the roof trims and are designed to fit all depths as they can be cut to fit the trims being used.

- **C1 Universal External Corner Trim** - forms a left or right hand corner.
Use with the “A” and “B” range of trims.
- **C2 Fillet to Corner Trim** - are used where a flat roof meets an abutting wall.
Use with the “A” range, “B” range and “D260” trims.
- **C3 Internal or External Fillet Corner Trims** - used as a preformed internal or external corner.
Use with a “D260” trim.
- **C4 Universal Internal Corner Trim** - forms a left or right hand corner.
Use with the “A” and “B” range of trims.

Trim colour may vary from those illustrated.



FIX-R C100/C150 Simulated Lead Flashing

Simulated lead flashing trims with two different depths - these are used to finish the D260 wall fillet and should be bonded using Fix-All adhesive.

- C100 (35 x 100mm)
- C150 (35 x 150mm)



FIX-R D260 Wall Fillet

Wall fillet used to fit up wall to allow for expansion of the roof.

- D260 (120 x 60 x 80mm)



FIX-R G150/G275 External 90° & H150/H275 Internal 90° Angle Trims

For use in areas such as walls and steps when the laminated surface sits flat to a perpendicular surface.

Finishing on the G trims is on the outer face.

Finishing on the H trims is on the inner face.

- G150 (75mm x 75mm)
- G275 (200mm x 75mm)
- H150 (75mm x 75mm)
- H275 (200mm x 75mm)



FIX-R E280 Pre-formed Expansion Joint/ Ridge Roll

Used on both the creation of expansion joint on roofs 50m² and above and to create a lead roll effect when joining the GRP roof to adjoining felted roofs.



FIX-R ER40/30 Pre-formed Rib Detail

Trim used to create raised rolled lead joint effect.

- Use the C6 closures to cap the ends
- ER40/30 (50 x 40mm)



FIX-R C5 & C6 Closure Trims

- The C5 roof ridge closure is used to finish E280 trim.
- The C6 roof ridge closure is used to finish ER40/30 trim.



FIX-R G180 Gutter Trim Expansion Joint

G180 Gutter trim for creating expansion joints on areas of 50m² or larger as well as creating a drainage channel, a sufficiently size channel needs to be cut into the deck for the trim to sit in.

- G180 (15 x 140mm)



FIX-R J380 35° - 50° Flexible Internal Angle

For use on internal angles between 35° and 50° from a flat surface.

- J380 (85 x 300mm)



FIX-R F300, F600 & F900 Flat Sheets

Preformed rolls of flat GRP flashing for use between flat and pitched roofs as well as other areas shown in trim guide.

- F300 (300mm x 20m roll)
- F600 (600mm x 20m roll)
- F900 (900mm x 20m roll)

Simple and fast installation with the FIX-R GRP system and accessories

PREPARATION

What do i need?

Below is a guide to what you should have before starting, check material and catalyst chart for calculating quantities needed.

Must-have components

- **FIX-R FLEXI-GRP Primer**
- **FIX-R FLEXI-GRP**
- **FIX-R GRP Standard or Winter Catalyst**
- **FIX-R GRP 300, 450 or 600g CSM (Chopped Strand Mat)**
- **FIX-R -GRP 75mm Woven glass tape**
(other widths available)



PREPARATION

Appraising type of installation

Due to the innovation of the FIX-R FLEXI-GRP system it can be applied to a range of surfaces which means that existing roofs deemed to be sound (see below) can be overlaid with FLEXI-GRP, meaning that a substantial amount of time and cost can be saved by overlaying suitable roofs. Not all roofs will be suitable without remedy first, the guide below details suitability. The FLEXI-GRP system can also be laid onto new OSB3 where the roof deck requires replacement.

Overlaying existing roof - Appraising roof condition

When appraising an existing roof, care must be taken to identify potential defects and points of failure prior to installation, all defects or points of failure should be remedied before commencing further. It is strongly recommend that core samples are taken to ascertain the existing structure and the condition of the underlying substrate as this forms part of the guarantee. Where roofs are completely sodden or saturated it would be recommended that the affected areas are removed and replaced with suitable materials to make the roof sound. When an area is defective through decay or wear it must be cut out and repaired to form a solid surface for the application of FLEXI-GRP. Please refer to the separate guide on preparation of different surface materials that are in common use.

Please remember to read through the guide fully on the suitability of surfaces that can be overlaid, FLEXI-GRP has been designed to perform on a range of roofing materials however due to a wide variety of seemingly similar materials that vary in manufacture and quality, it is recommended that a small area is tested for the strength of bond before commencing the main body of work.

Part of the appraisal should take into account the existing detailing such as upstands, drip trims and outlets, these will form part of the overall system and need to be in suitable condition to avoid a system failure, any redundant or failed details need to be either removed or replaced prior to application.

OSB3 INSTALLATION GUIDE

Simple and fast installation with FIX-R GRP System and accessories.

This guide and datasheets are available at www.fix-r.co.uk. The key to any work is good preparation and making sure you are familiar with the 'Do's & Don'ts' of laying FLEXI-GRP before starting, take time to familiarise yourself with this guide and make it a great FLEXI-GRP experience every time.

A. Preparation

- 1** Before starting make sure that the weather forecast is fair as rain will affect the cure and finish of any GRP system, ensure areas around the installation that are liable to resin splashes/drips are covered or moved where possible, such as vehicles, windows etc.
- 2** Remove any old roof coverings, chippings or rotten wood for over boarding or full replacement using 18mm OSB 3.
- 3** Ensure temperature is above 7.5°.
- 4** All materials should be stored suitably between 15-25° before use.
- 5** Use the material estimation guide to make sure you have everything you need to do the job.
- 6** Read the catalyst addition guide to take account of the temperature on the day of installation.
- 7** If your not sure of anything, stop and ask our technical team for help and guidance, we always recommend asking about our training and demonstration days to really see the product in action.

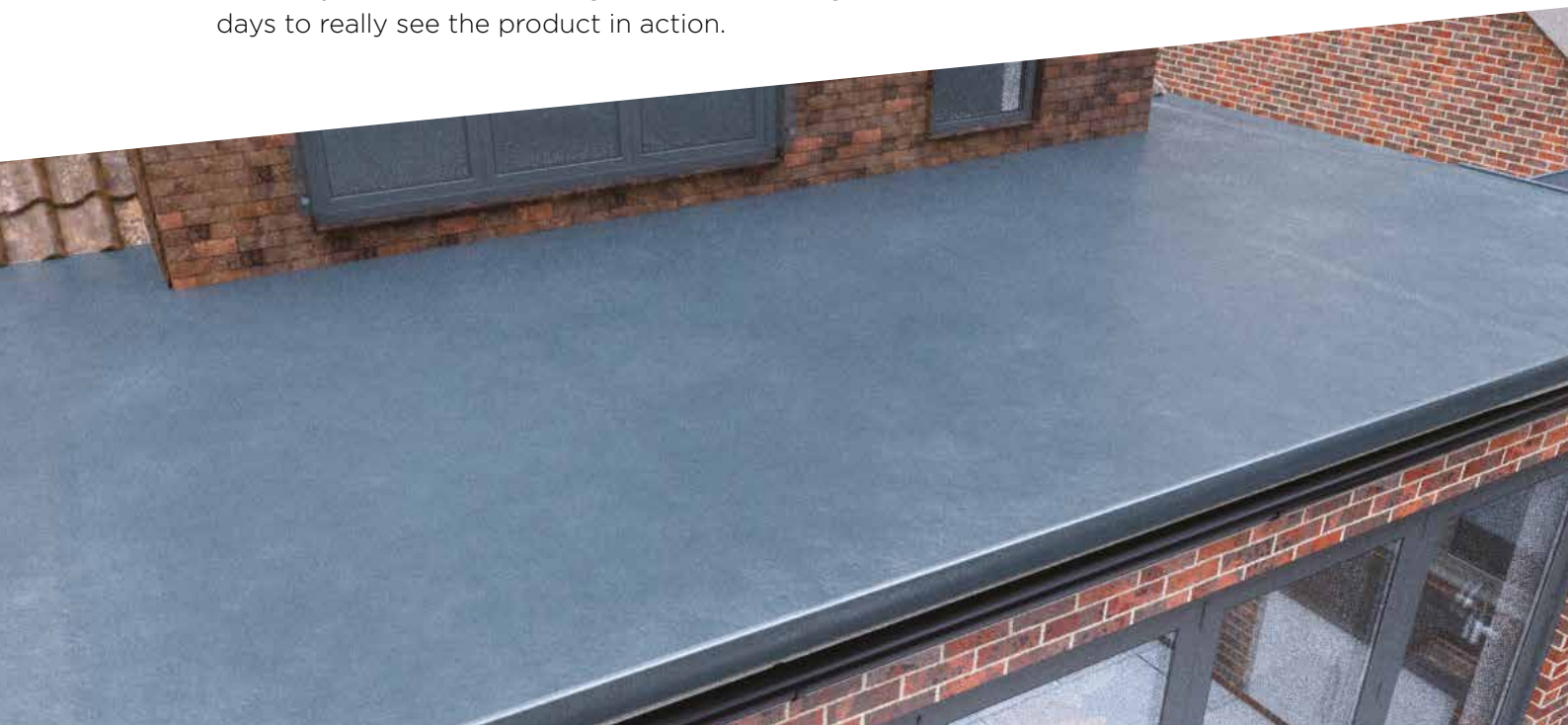

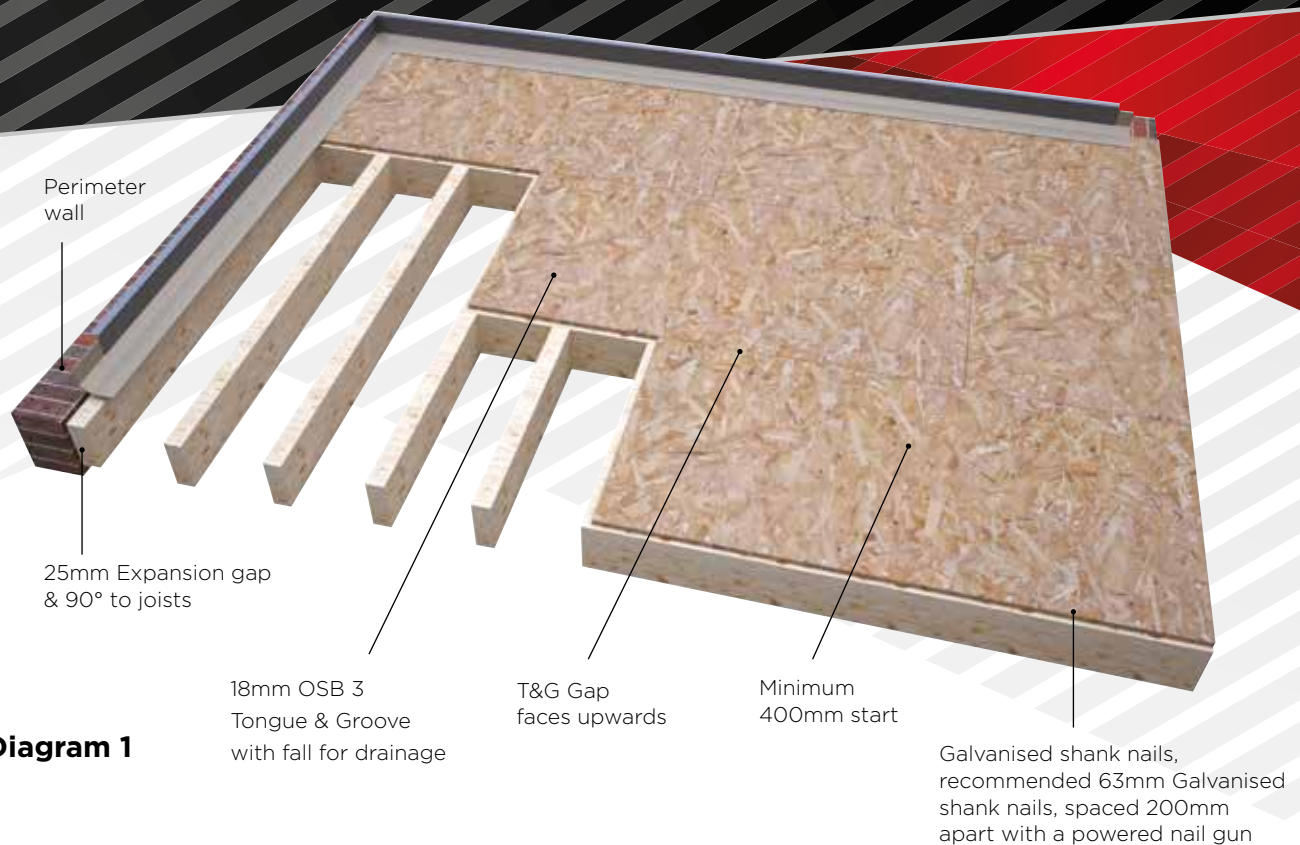

Diagram 1

B. Preparing the deck

Like any good construction it's only as good as its foundations and the same is true for GRP, please read through the guidelines below if you are preparing the deck or pass along to the contractor who is, so you can be sure you're ready to go.

Key Features/Benefits:

1 Examine existing roof boards and either remove if rotten or warped, or overboard if suitable, ensuring that all existing roofing materials such as felt, bitumen, single ply etc is removed prior to over boarding. Whether overboarding or laying a new deck it is vital that the boards are not exposed to rain or excess moisture prior to applying the FLEXI-GRP system as this can lead to movement of the boards and potential failure of the roof.

NB If using 18mm Tongue & Groove OSB 3 board have the gap of the tongue & groove facing upwards when laying. If laying square edge OSB3 the joints must be taped using the 75mm FIX-R GRP Woven GRP Tape.

2 The boards must be laid 90° to the joists or existing boards ie across joists/boards and not inline (See diagram 1) making sure there is sufficient fall built in to allow the surface to drain without standing water. When laying next to a wall allow a 25mm gap between the board and wall, this allows for the movement of the roof during hot and cold weather and avoids the excessive noises associated with poorly installed decks. Finish the board flush to the fascia and then stagger the next row of board with a minimum of 400mm board to start.

3 Fix the boards with a galvanised ringshank nail (recommended 63mm) to penetrate the joists by 40mm the fixings should be spaced 200mm apart. We recommend a powered nail gun to fix the nails in place as this makes the job considerably quicker and avoids damaging the ceiling below. Standard hammers can be used in areas that have no ceiling below, please ask about the correct fixings when installing a roof with insulation.

4 It is vital to note that any one flat area above 50m² must include an expansion joint (see GRP Trim Installation Guide from page 18).

Surface Preparation For Overlay

The key to all flat roofing systems to give good long-term performance is correct surface preparation, and the same is true for FIX-R FLEXI-GRP. Please read through the guidelines below if you are preparing the surface or pass along to the contractor who is. This is to ensure that all necessary evaluations and surface prep has been carried out as per these guidelines and good working practices .

- 1.** The vital part of the installation is to ensure that the surface and the substrates beneath are not wet, laying on wet materials will lead to a failure of the system through lack of bond between materials, this should be the case for virtually all liquid systems and not just in the case of FLEXI-GRP. This point cannot be over emphasised as in the majority of cases, roof failure is caused by poor preparation prior to application.
- 2.** Check the moisture content of the surface and underlying substrates carrying out a core sample and a good quality moisture meter with a maximum moisture content reading of 20% WME (wood measurement equivalent), above this level the moisture is considered hazardous, especially with wood as this is considered the point of where wood starts to rot and will require further investigation.
- 3.** Surface water must be removed and it is recommended to address areas that show ponding as this will also pond on the finished surface once completed. Ponding may indicate that either the roof deck has started to fail, that the supporting trusses are bowed or that the original roof was not designed with sufficient fall in the first place. If the substrates are showing a higher than 20% WME reading then it must either be allowed to dry out naturally or the use of forced drying using warm air dryers. Direct flame drying should be avoided due to the risk of fire.
- 4.** All surfaces must have the following treatment prior to application (individual preparation set out in addition).
 - Remove all loose surface materials such as chippings, any embedded chippings must be removed by mechanical means.
 - All areas should be cleaned, removing dirt, debris, organic growth such as moss and lichen.
 - NB: If areas contain asbestos, seek specialist advice as these area's should not be disturbed or mechanically cleaned due to the hazardous nature of asbestos roofing.
 - Areas that have had organic growth should be treated with an antifungal spray or distilled vinegar can be used as a safe environmental alternative, allow moss and lichen to die back and remove with a stiff bristle broom or similar.

Surface preparation (continued)

- **Felt** – Remove damaged or badly decayed areas to ensure a sound surface is achieved to lay FLEXI-GRP on. Blisters should be star cut, peeled back, allowed to dry then rebonded to the substrate before further application, this also applies to loose felt if in good condition. Prime with FLEXI-GRP Primer before applying the FLEXI-GRP liquid.
- **Asphalt** – Areas with cracks above 5mm should be cleaned and made good with a suitable repair adhesive/compound such as Fix-All, areas that have blown need to be levelled with a suitable repair compound such as FIX-Rcyl. Allow all repairs to properly cure before applying FLEXI-GRP Primer.
- **GRP/Fibreglass** – Remove any flaking, cracked or loose topcoat and sand back to a firm base, for best results it is recommended that a light surface sanding is carried out followed by an acetone wipe using FIX-R GRP Acetone, this should include any existing trims that also need to be laminated in the same way as the main roof, primer is not required but would be recommended if a higher strength bond was desirable.
- **Concrete/Brick & Screed** – Smooth concrete should be lightly abraded to achieve a clean dry surface. Remove any loose debris and any cracks of areas that have broken out should be repaired with a suitable compound and allowed to cure prior to application. Wet surfaces must be dry thoroughly before application, application to fresh concrete/screed (under 30 days) is not recommended unless full cure of the concrete is achieved. Prime surface with FLEXI-GRP Primer, failure to do so will lead to a system failure and invalidate the guarantee.
- **Metals** – FLEXI-GRP can be used on common metals used in general construction of a combined roof. FLEXI-GRP should not be considered if laying on to an all metal surface rather where fixtures, fitting form part of a standard roof construction. It is not recommend to overlay onto rusting metal, if it is not possible to remove/replace it would require a rust convertor based on phosphoric acid that would need to be cleaned and dried as per manufacturers instructions. Clean, abrade and acetone wipe prior to application of FLEXI-GRP Primer, ensure PPE is correctly used when handling lead in particular. Once primer has lost most of it's tack then the FLEXI-GRP can be applied. Primer will be active for approximately 1 hour, if left for longer then a second coat of FLEXI-GRP Primer should be applied.

C. Applying the GRP Trims

FIX-R GRP trims are essential for giving the finished roof its performance and appearance to your customer, having consulted the industry widely, our trims have been designed to be easier to handle, transport and fit with less waste, saving time, money and the environment.

- 1** There are a full range of trims and each have a different use (see Trim Installation Guide for sizes and use). When you have selected the correct trims for the job the same application details apply to the range.
- 2** The trims should be fixed to the perimeter of the roof (diagram 2), apply a 6-8mm bead of Fix-All adhesive/sealer on the perimeter of the OSB 3 for the trim to bed in, use 13mm clout nails/staples to fix the trim into position. Firstly fix each end of the trim, then the middle and then in between with spacing of approx. 200mm between, note that trims have a matt surface and a gloss surface, the matt surface should always be used to overlay with the resin and fibreglass matting.
- 3** When using drip trims (A170/A200/A250) it is recommended to use an electrical planer to remove 2mm of the OSB 3 at the perimeter to allow the trim to lay flush with the deck to prevent any drainage issues/ponding.
- 4** Apply the 75mm woven glass edging tape with approximately half on the trim edge and half on the OSB 3, in preparation for the resin and fibreglass layer (See diagram 3).
- 5** Corners should be selected and used to ensure the best fit between drip trims, raised edge trims and where the trims terminate against the wall.
- 6** Where the edge of the OSB 3 meets a vertical wall a fillet trim must be used (D260) to bridge the 25mm expansion gap and form the upstand, this is then finished off with the simulated lead flashing trim (C100) which must be rebated into the brickwork/mortar line by using an angle grinder to make a 35mm chase cut, this forms protection from water coming down the brickwork and behind the fascia trim. Bond the (C100) into place using Fix-All adhesive/sealer.

Diagram 2



35mm Rebate into
brickwork/mortar line

D260 Fillet/Upstand
with C100 type
simulated lead flashing

Raised edge trim
B260/B300

Diagram 3



75mm Woven GRP Tape

GRP TRIMS INSTALLATION GUIDE

A170/A200 & A250 Drip trims in situ

These trims should be fitted to the lowest point of the roof to allow for the flow of water into the gutter.

Support battens should be used to create a gap from the gutter to stop the trim flexing out of position - fix in place with FIX All adhesive. Clout nails should be used to fix the trim to the deck - do not nail the trim to the battens.

To create a continuous run overlap by 50mm the first trim with the next and bond with FIX All adhesive. Finish off by applying the FIX-R woven glass tape with catalysed FLEXI-GRP.

Allow to go hard and then lightly sand before finishing with catalysed FLEXI-GRP.

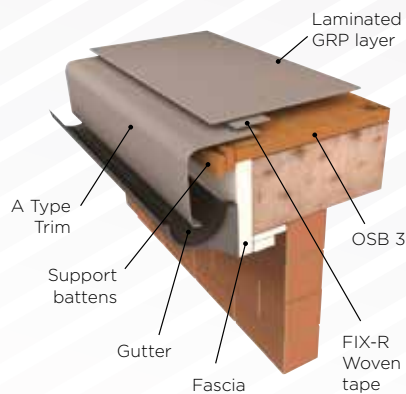

B240/B260 & B300 Raised edge trims in situ

The trims should be used to prevent water flowing over the edge of the roof with the use of batten to support the trim and prevent flexing out of position. Fix in place with Fix All adhesive.

Clout nails should be used to fix the trim to the deck - do not nail the trim to the battens.

To create a continuous run overlap by 50mm the first trim with the next and bond with FIX All adhesive. Finish off by applying the FIX-R woven glass tape with catalysed FLEXI-GRP.

Allow to go hard and then lightly sand before finishing with catalysed FLEXI-GRP.

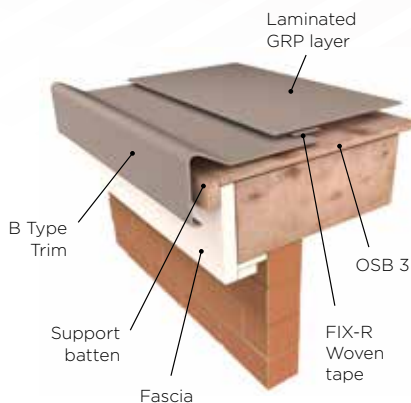

D260/C100 & C150 Wall fillet and simulated lead flashing in situ

D260 trims should be fitted against walls to provide an upstand and to allow for a 25mm gap of the deck board from the wall.

C Trims should be used to complete a water tight finish and to rebate the mortar line about the D260 trim to a depth of 35 - 45mm.

The edge of the C Trim should be fitted in the rebate and sealed with Fix All adhesive.

Clout nails should be used to fix the trim to the deck - do not nail the trim to the battens.

To create a continuous run overlap by 50mm the first trim with the next and bond with FIX All adhesive. Finish off by applying the FIX-R woven glass tape with catalysed FLEXI-GRP.

Allow to go hard and then lightly sand before finishing with catalysed FLEXI-GRP. NB do not topcoat the C trim as it is not required.

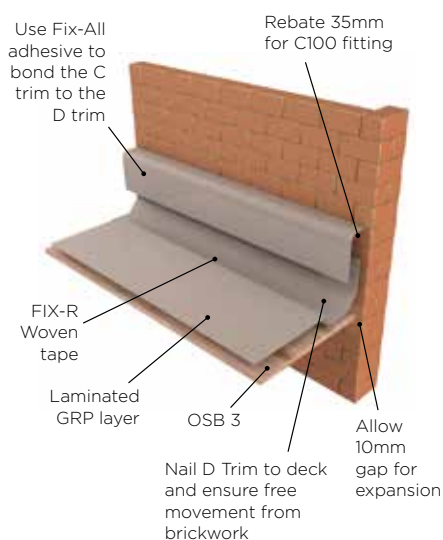

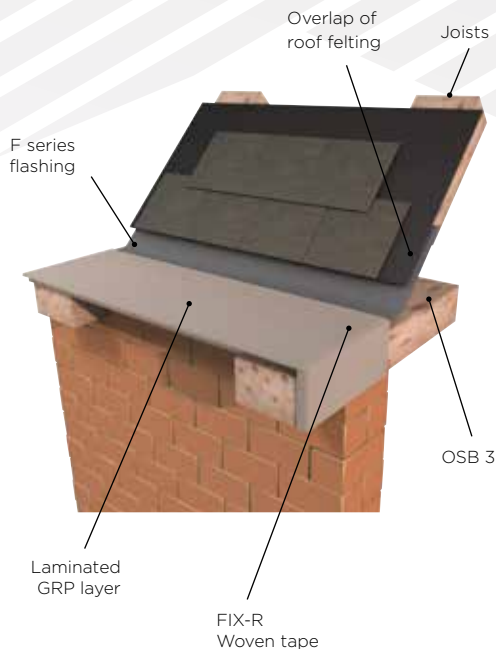

F300/F600 & F900 Flat flashing in situ

The F series flat flashing is used when a pitched roof meets a flat roof. Clout nails are used to fix the flashing to the deck.

Then form the shape at an angle to underneath the roof felt and tiles.

The F series flat flashing can also be used to form around vertical surfaces.

To create a continuous run overlap by 50mm the first trim with the next and bond with FIX All adhesive. Finish off by applying the FIX-R woven glass tape with catalysed FLEXI-GRP.

Allow to go hard and then lightly sand before finishing with catalysed FLEXI-GRP.

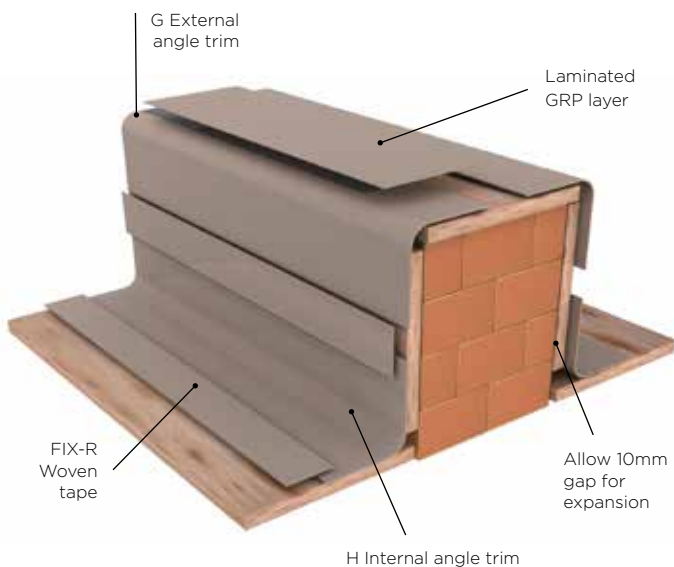

G150 & G275 90° External angled trims and H150 & H275 90° Internal angled trims in situ

The G & H series of trims are used to form over a parapet wall or similar features.

Clout nails should be used to fix the trim to the deck - do not nail the trim to the battens.

To create a continuous run overlap by 50mm the first trim with the next and bond with FIX All adhesive. Finish off by applying the FIX-R woven glass tape with catalysed FLEXI-GRP.

Allow to go hard and then lightly sand before finishing with catalysed FLEXI-GRP.

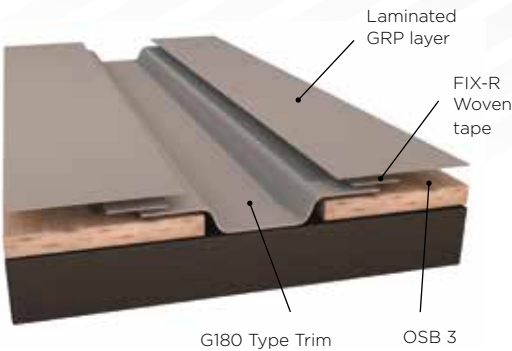
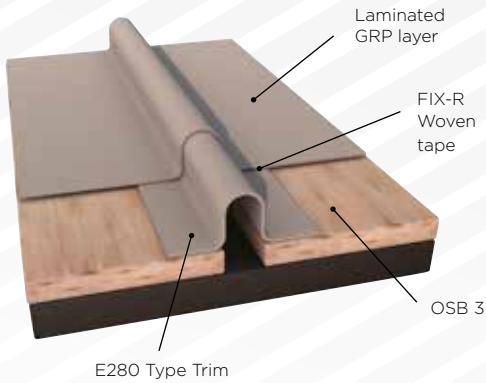

E280 & G180 Expansion joints in situ

Use either the E280 or G180 gulley trim to form expansion joints on single formed areas over 50m². The appropriate width should be cut in the deck to accommodate the trim type used. Either can be used however the G180 gulley trim gives the added benefit of channelling water for drainage. The E280 trim should be finished with a C5 closure.

Clout nails should be used to fix the trim to the deck - do not nail the trim to the battens.

To create a continuous run overlap by 50mm the first trim with the next and bond with FIX All adhesive. Finish off by applying the FIX-R woven glass tape with catalysed FLEXI-GRP.

Allow to go hard and then lightly sand before finishing with catalysed FLEXI-GRP.

ER40/30 Pre-Formed Rib detail in situ

The ER40/30 trim is used to create the simulation of raised lead roll effect joints.

Clout nails should be used to fix the trim to the deck - do not nail the trim to the battens.

To create a continuous run overlap by 50mm the first trim with the next and bond with FIX All adhesive. Finish off by applying the FIX-R woven glass tape with catalysed FLEXI-GRP.

Allow to go hard and then lightly sand before finishing with catalysed FLEXI-GRP.

Use C6 closures to finish the ends.

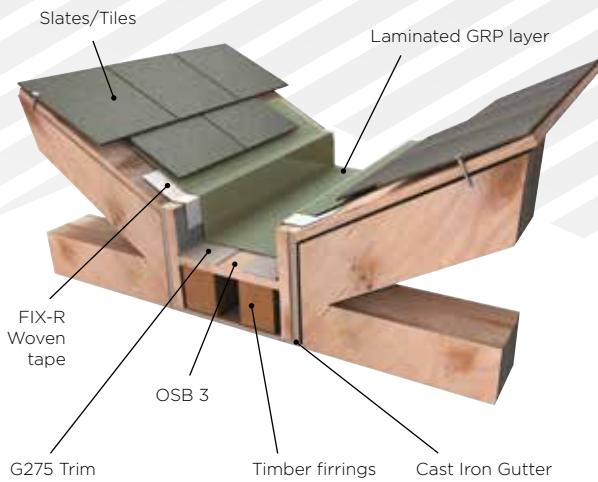

Repairing box gutters between pitched and pitched/walled roofs

To raise the slates/tiles lay a OSB 3 the length of the roof and then use cut lengths into the box gutter supported by firrings to create a surface to form a sealed surface with the appropriate trims and laminated GRP.

Clout nails should be used to fix the trim to the deck - do not nail the trim to the battens.

To create a continuous run overlap by 50mm the first trim with the next and bond with FIX All adhesive. Finish off by applying the FIX-R woven glass tape with catalysed FLEXI-GRP.

Allow to go hard and then lightly sand before finishing with catalysed FLEXI-GRP.

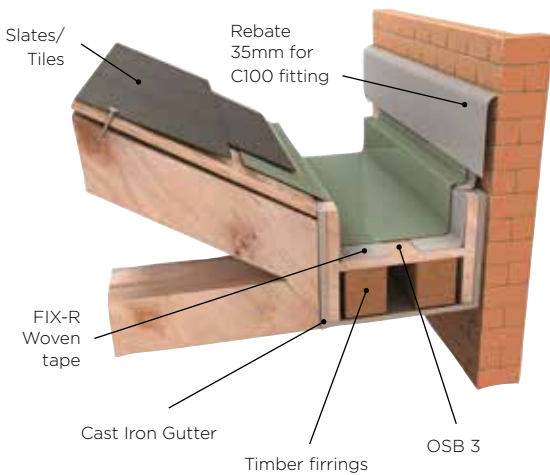

E280 Pre-Formed Rib to form a joint to a felt roof in situ

The E280 can be also used to form a joint between an existing felt roof and the GRP roof, by lifting the adjoining felt and bond the trim with Fix-All adhesive both to the felt and the deck, use an additional bead where the lip of the felt meets the trim to form a watertight seal.

Clout nails should be used to fix the trim to the deck - do not nail the trim to the battens.

To create a continuous run overlap by 50mm the first trim with the next and bond with FIX All adhesive. Finish off by applying the FIX-R woven glass tape with catalysed FLEXI-GRP.

Allow to go hard and then lightly sand before finishing with catalysed FLEXI-GRP.

Use C5 closures to finish the ends.

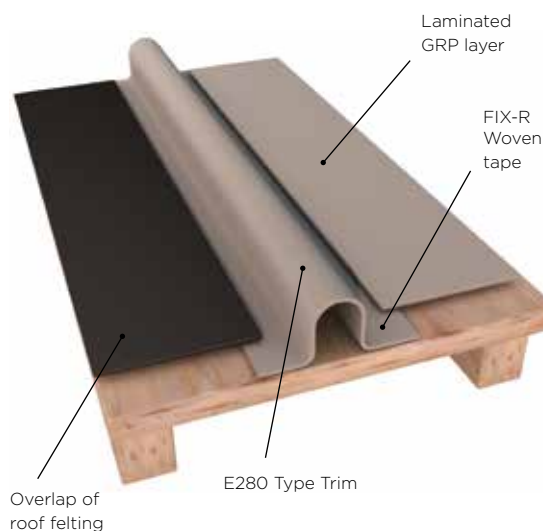

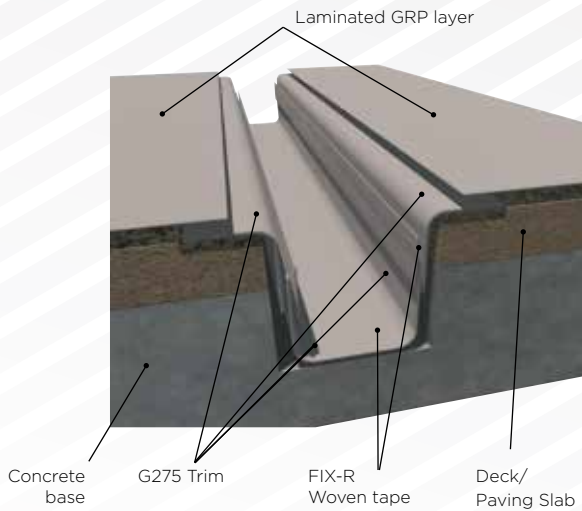

G275 Trim to form gulley detail in situ

Use the G275 to form the shoulders of the gutter and the base of the gulley, fix with nails if boarded and use Fix-All adhesive in both instances if bonding to concrete. Tape all joints to ensure a strong gulley.

To create a continuous run overlap by 50mm the first trim with the next and bond with FIX All adhesive. Finish off by applying the FIX-R woven glass tape with catalysed FLEXI-GRP.

Allow to go hard and then lightly sand before finishing with catalysed FLEXI-GRP.

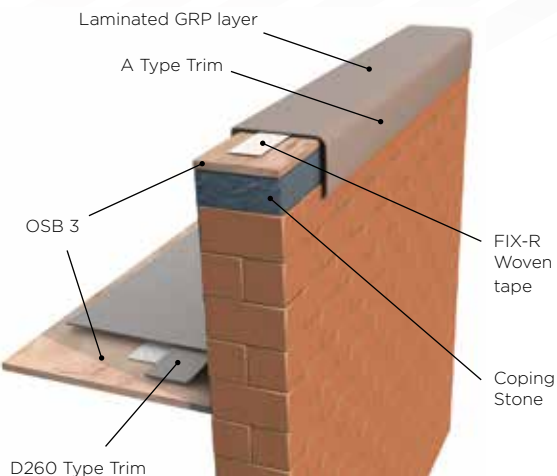

Forming GRP over parapet wall with coping stone in situ

To ensure a fully sealed system is achieved when laying roofs with parapet walls it is strongly advised to form the GRP up the vertical of the wall over the coping stone and terminating in a A type drip trim

Lay the GRP in the normal manner using a D260 upstand then use the F series flashing up the wall and an A type drip trim to finish the drop on the back face of the parapet.

Clout nails should be used to fix the trim to the deck - do not nail the trim to the battens.

To create a continuous run overlap by 50mm the first trim with the next and bond with FIX All adhesive. Finish off by applying the FIX-R woven glass tape with catalysed FLEXI-GRP.

Allow to go hard and then lightly sand before finishing with catalysed FLEXI-GRP.

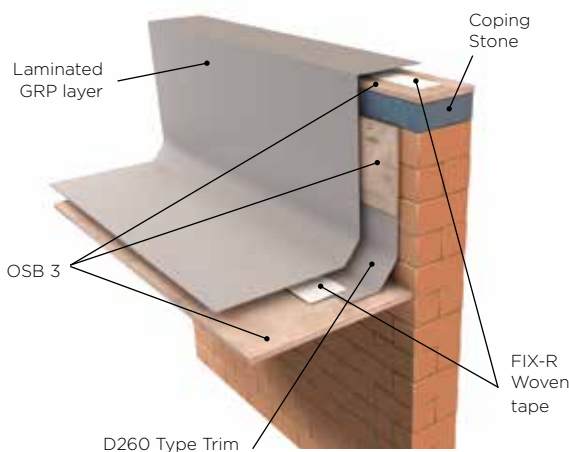

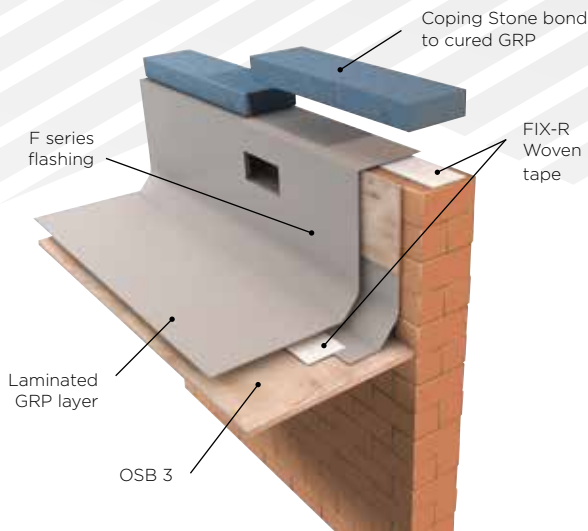

Forming GRP outlet through a parapet wall with coping stone

To form a lined outlet it is recommended that this is formed in conjunction with the trims being fixed. Lay the GRP in the normal manner using a D260 upstand then use the F series flashing up the wall and cut the F trim to form the outlet, trim an A type trim on the back face of the wall to create a fall to the gutter.

Clout nails should be used to fix the trim to the deck - do not nail the trim to the battens.

To create a continuous run overlap by 50mm the first trim with the next and bond with FIX All adhesive. Finish off by applying the FIX-R woven glass tape with catalysed FLEXI-GRP.

Allow to go hard and then lightly sand before finishing with catalysed FLEXI-GRP.

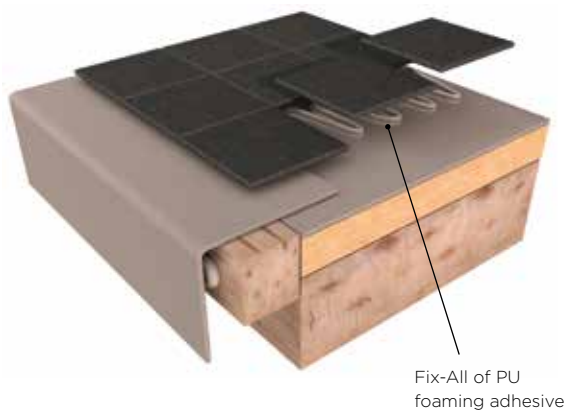

Laying rubber & promenade tiles

When laying tiles onto the formed GRP roof it is strongly recommended that this is done within a short time of the GRP curing to achieve the best bond, if this is done post installation then the GRP will need to be lightly abraded, wiped clean with FIX-R Acetone cleaner. Ensuring the surface is clean dry and free of debris proceed to lay the tiles using either Fix-All adhesive with a zig-zag pattern with a bead size of 8-10mm or an expanding PU Adhesive.



Forming GRP on UPVC pipe

GRP can be formed around and into UPVC pipes by abrading the UPVC first, in addition any cementitious collars should be primed along with the UPVC using G4 sealer prior to forming the GRP around the pipe. To finish the pipe correctly it is recommended wrapping the uppermost part in the FIX-R woven tape and resin to form a neat collar, finish with topcoat in the normal manner.

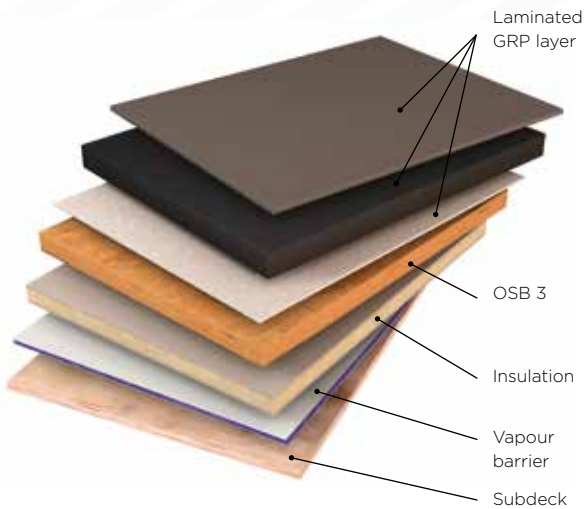

Warm Roof construction in situ

Forming a warm roof with GRP is achieved by laying a sub deck on the joists with 300mm centres, a vapour barrier is laid next then the insulation layer, preferably use insulation with a built in vapour barrier.

Either mechanically fix the OSB 3 to the joists below or fully bond with an expanding PU adhesive. Then form the GRP roof in the normal manner.

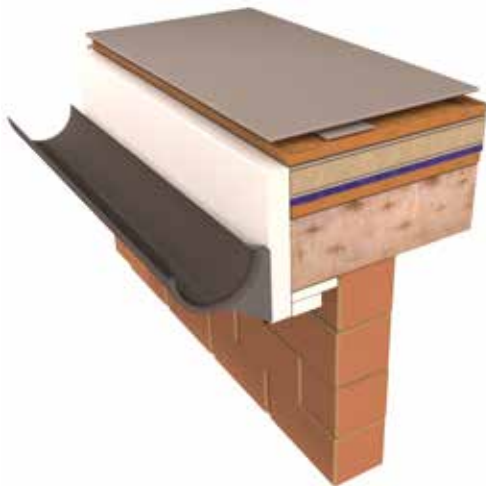

CATALYST ADDITION CHART FOR FLEXI-GRP PRIMER & FLEXI-GRP

Surface/FLEXI-GRP Temperature	28-35°C	20-27°C	12-19°C	6-11°C	0-5°C
Percentage Catalyst	1% Standard Catalyst	2% Standard Catalyst	3% Standard Catalyst	2% Winter Catalyst	3% Winter Catalyst*
Weight of resin/topcoat	Weight or volume of catalyst (ml/g)				
1kg	10ml	20ml	30ml	20ml	30ml
2kg	20ml	40ml	60ml	40ml	60ml
3kg	30ml	60ml	90ml	60ml	90ml
4kg	40ml	80ml	120ml	80ml	120ml
5kg	50ml	100ml	150ml	100ml	150ml
6kg	60ml	120ml	180ml	120ml	180ml
7kg	70ml	140ml	210ml	140ml	210ml
8kg	80ml	160ml	240ml	160ml	240ml
9kg	90ml	180ml	270ml	180ml	270ml
10kg	100ml	200ml	300ml	200ml	300ml
15kg	150ml	300ml	450ml	300ml	450ml
18kg	180ml	360ml	540ml	360ml	540ml

* NB: Whilst FLEXI-GRP can be used in cold/dry conditions any work should be completed and cured before nightfall or before temperatures fall sharply.

Do's & Don't's

- To achieve the most accurate catalyst addition always weigh the FLEXI-GRP Primer or FLEXI-GRP in a bucket and then add the correct amount of catalyst using a dosimeter
- In hot weather never go below 1% addition of standard catalyst, if still to quick mix up less FLEXI-GRP Primer or FLEXI-GRP
- Never use more than 3% of Winter Catalyst in cold weather as this can affect the performance of the system
- The more FLEXI-GRP Primer or FLEXI-GRP you mix the hotter it will get the longer you leave it in the mixing bucket, it would be advised to mix under 5kg at a time to ensure the best working time is achieved.
- If material has gelled and cannot be used move to a safe location away from flammable materials
- Always stir every mix thoroughly to ensure a streak free finish and fully cured finish.
- If in doubt – Ask for advice.

USING FLEXI-GRP PRIMER

FLEXI-GRP Primer is a high performance multi surface primer that promotes the adhesion between different surfaces and FLEXI-GRP, for use when overlaying existing roofing surfaces or new surfaces where primer is recommended. Refer to surface preparation section for specific surfaces and how to treat them prior to application of the FLEXI-GRP system. Use FLEXI-GRP in dry conditions and do not apply to wet or damp surfaces, care should be taken that rain is not imminent.

Coverage Rates & Quantities

Materials Usage Guide (NB guide does not account for materials lost in mixing or use of brushes/rollers etc)			
Roof Size m²	Smooth Surfaces 200g per m²	Medium Surfaces 250g per m²	Rough Surfaces 300g per m²
5	1kg	1.25kg	1.5kg
10	2kg	2.5kg	3kg
15	3kg	3.75kg	4.5kg
20	4kg	5kg	6kg
25	5kg	6.25kg	7.5kg
30	6kg	7.5kg	9kg
35	7kg	8.75kg	10.5kg
40	8kg	10kg	12kg
45	9kg	11.25kg	13.5kg
50	10kg	12.5kg	15kg
75	15kg	18.75kg	22.5kg
100	20kg	25kg	30kg

NB: FLEXI-GRP Primer uses the same catalyst as the FLEXI-GRP and the same addition rates making it easier to calculate. Please refer to the Catalyst Addition Chart for the addition rate for both.

Calculate the area and amount required to cover the surface and all associated fixtures and fittings that will be covered in FLEXI-GRP and allow for approx. 5% waste that is lost in the mixing and application process. Working times can be adjusted easily and quickly depending upon changing weather conditions, the working time should be around 15-20 minutes per mix. Allow 30-40 minutes to cure before applying the FLEXI-GRP. It is not recommended to leave the application of the FLEXI-GRP longer than 48hrs after the FLEXI-GRP Primer has been applied.

FLEXI-GRP COVERAGE GUIDE

Coverage Rates & Quantities

Roof Size m ²	300g Smooth surface 15 Year	450g Smooth surface 20 Year	600g Smooth surface 25 Year*	300g Medium surface 15 Year	450g Medium surface 20 Year	600g Medium surface 25 Year*	300g Rough surface 15 Year	450g Rough surface 20 Year	600g Rough surface 25 Year*
5	7.5kg	9.75kg	12kg	8.25kg	10.9kg	13.5kg	9kg	12kg	15kg
10	15kg	19.5kg	24kg	16.5kg	21.8kg	27kg	18kg	24kg	30kg
15	22.5kg	29.25kg	36kg	24.75kg	32.7kg	40.5kg	27kg	36kg	45kg
20	30kg	39kg	48kg	33kg	43.6kg	54kg	36kg	48kg	60kg
25	37.5kg	48.75kg	60kg	41.25kg	54.5kg	67.5kg	45kg	60kg	75kg
30	45kg	58.5kg	72kg	49.5kg	65.4kg	81kg	54kg	72kg	90kg
35	52.5kg	68.25kg	84kg	57.75kg	76.3kg	94.5kg	63kg	84kg	105kg
40	60kg	78kg	96kg	66kg	87.2kg	108kg	72kg	96kg	120kg
45	67.5kg	87.75kg	108kg	74.25kg	98.1kg	121.5kg	81kg	108kg	135kg
50	75kg	97.5kg	120kg	82.5kg	109kg	135kg	90kg	120kg	150kg
60	90kg	117kg	144kg	99kg	130.8kg	162kg	108kg	144kg	180kg
65	97.5kg	126.75kg	156kg	107.25kg	141.7kg	175.5kg	117kg	156kg	195kg
70	105kg	136.5kg	168kg	115.5kg	152.6kg	189kg	126kg	168kg	210kg
75	112.5kg	146.25kg	180kg	123.75kg	163.5kg	200.5kg	135kg	180kg	225kg
80	120kg	156kg	192kg	132kg	174.4kg	216kg	144kg	192kg	240kg
85	127.5kg	165.75kg	204kg	140.25kg	185.3kg	229.5kg	153kg	204kg	255kg
90	135kg	175.5kg	216kg	148.5kg	196.2	243kg	162kg	216kg	270kg

NB: Coverage figure quoted should only be seen as a guide due to variances in surface type and waste when using buckets, brushes, rollers etc

APPLYING FLEXI-GRP

FIX-R FLEXI-GRP system is an evolution in the use and application of “traditional” GRP Systems and has been specifically developed to meet the rigorous demands of flat roofing. This allows the options to either overlay existing flat roofs (that have been assessed as suitable) and applications onto new OSB3 decks.

FIX-R FLEXI-GRP not only gives long-term protection and weather resistance but has also achieved the highest fire rating available for flat roofing, BS476 Part 3/CEN/TS EN1187 when laid onto an OSB3 Deck. Thus giving top fire performance onto a surface that is used in every day flat roof construction and complying with building regulations.

Prior to commencing the main field area installation (after the primer has been applied) mix up the quantity of resin that you require to laminate the reinforced glass tape onto any perimeter edge trims and corners. This will help you decide on what working time for the main installation of the chopped strand mat (CSM) will suit you, the normal working time for the resin should be around 20 minutes per mix, never mix a container above 5kg in weight as this will potentially cure in the container if you cannot lay it in time.

1. Use the FLEXI-GRP coverage guides to calculate how much FLEXI-GRP Primer and FLEXI-GRP will be required to complete the installation. This will be determined on the weight of the CSM (chopped strand mat) chosen and surface finish. Using heavier weight matting achieves a longer materials guarantee. Also insure you have sufficient FIX-R Catalyst and the correct grade for the time of year (Standard or Winter).
2. Once all of the relevant surface preparation has been carried out you are ready to start installing the system. The CSM should be laid in the direction of the fall of the roof to help drainage and avoid areas of standing water, you will be laying in rows of CSM which are approx. 975mm wide allowing for the feathered edge, CSM has a straight cut edge and opposite is the feathered edge which will be used to integrate the next row of CSM using a 50mm overlap. If this done correctly you can achieve a virtually seamless joint that will look aesthetically better and aid drainage. Work should commence on the outer perimeter away from the main wall if one exists, start with the straight cut edge of the mat. Best practice is to pre-measure and cut the rows of CSM prior to applying the FLEXI-GRP, this will ensure you have the maximum working time of the materials.
3. Always fully stir the FLEXI-GRP in the original container before pouring into a secondary container. Use a plastic paint stirrer or similar ensuring the mixer is clean. Do not use an electrical stirrer/paddle mixer as this will introduce excessive air into the mixture that could lead to pinholes in the cured product. Once completely stirred the FLEXI-GRP can be poured into an appropriate bucket or scuttle, to get the best accuracy and to ensure a consistent cure rate the material should be weighed using either portable battery operated scales or hand scales. Using a dosimeter measure the correct amount of standard or winter FIX-R GRP Catalyst, mix into the container using a separate stirrer to avoid introducing catalysed material into the original container, the catalyst must be stirred in fully to the bottom of the container. Handle catalyst with care and store in shade when not in use, use the correct PPE ie gloves and safety glasses, a mask can be worn if desired.
4. Having calculated what you will need for each run mix in batches of approximately 5kg lots, you should calculate that you will need 600g per m² as the finishing coat, this applies to all weights of CSM and surface finish, e.g. 1m² @300g smooth = 900g + 600g finishing coat = Total 1.5kg m². Roller apply the FLEXI-GRP to the surface using a short pile velour then roll out the CSM into the FLEXI-GRP using the same velour roller to consolidate the CSM making sure there are no pockets of air and that the CSM is fully wetted with no white fibres remaining. On smooth surfaces and especially on new OSB3 decks it is recommend that a bubble buster or fin consolidating roller is used.

APPLYING FLEXI-GRP (cont)

5. Once the row is completed you have the choice to either finish the row wet on wet using the coverage rate at 600g per m² or for the best finish you should continue onto the next row. To do this apply the FLEXI-GRP as for the first row and again roll the CSM down into it, this time making sure the straight cut edge is laid into the feather edge of the previous row by 50mm, consolidate the joint with the velour roller or if onto a smooth surface use a fin roller to achieve the ultimate joint with low print through on the finished surface. Continue this process until meeting the end of the surface, i.e. a wall upstand or opposite side of roof edge, allow to cure for 45-60 minutes (dependant on weather conditions) then apply the 600g finish coat across the entire surface including perimeter trims etc, this will give the best aesthetic finish to the roof however both methods will achieve a full waterproofed envelope once cured.
6. For area's that require an anti slip surface, such as walkways you will need to apply Scangrit anti slip. This can either be broadcast into a 300g wet layer that is applied after the main roof has cured by mask taping the area that is to have the FLEXI-GRP applied then the Scangrit is broadcast by hand onto the wet FLEXI-GRP and allowed to cure (NB remove the mask tape whilst the FLEXI-GRP is still soft) or you can mix the Scangrit directly (using 10-15% by weight) into the FLEXI-GRP and then apply onto the surface in the area marked by the masking tape.



FIXER

FLAT ROOFING

FLEXI-GRP

- 15-year (300g CSM), 20-year (450g CSM) or 25-year (600g CSM) Material Guarantee when installed correctly, please contact us for further details of the guarantee conditions.
- Single high-performance flexible resin used both as base and topcoat wet-on-wet application
- Can be applied to multiple surfaces for existing and new surfaces such as mineral felt, single ply, GRP, concrete, OSB3, asphalt
- Quick application and cure times
- Cold applied, no hot works or open flame risks
- Class beating Fire rating
Tested as a Flat Roofing System applied to OSB3 and has achieved both:
BS 476-part 3 test:- EXT.F.AA;
EN 1187 test 4 - BROOF(t4)
- Superior 'wet-out' of resin with fiberglass reinforcement (CSM).

*Please see full guarantee's for conditions



All the information in this product sheet is based on practical experience and is published in good faith. However, because we have no control over the manner or conditions in which our products are used, or over work undertaken or end product manufactured by the purchaser, we cannot accept liability for results. Responsibility for ascertaining the suitability of products for their purposes rests with the purchaser. All conditions, representations, statements, warranties or guarantees whatsoever, whether express, implied or statutory, in respect of any goods manufactured, sold or supplied by us are hereby expressly excluded and we accept no liability in respect of any claim for damage or consequential loss caused to any property arising directly or indirectly out of the use of our products or goods. FIX-R reserves the right to change product specifications without notice. VERS 1. 08/2020